

ACCEPTED SOFTWARE FORMATS

(PC Compatible files only)

Adobe Illustrator convert fonts to outlines.

Adobe Illustrator EPS convert fonts to outlines.

Adobe Photoshop this file type is not recommended for files including type as it diminishes the quality when printed.

Adobe photoshop EPS convert fonts to outlines.

PDF high resolutions, editable embed all included fonts.

Include all embedded and placed files. For more information on files formats contact our artwork department.

COLOURS FOR PRINTING

Files will be accepted in CMYK and Pantone colours only. Files in RGB will not be accepted. Pantone Colours ensure your artwork files specify the exact pantone colour names within the file. All pantones must also be included in your order form.

IMAGES

Photographs (jpeg, gif, bmp, png files) must be a minimum of 300dpi (resolution) at 100%.

note: photos that are imported into other applications and are enlarged, the resolution should be higher.

Vector art should remain as editable paths for optimal printing standards.

FONTS

All fonts used in the file must be supplied if outlines have not been created, including screen and printer fonts. Fonts must be supplied in True type format (windows) or Post Script (windows).

Following these simple steps and guidelines will help in the production of your printed piece and help maintain the high quality standards of PPC. This will also help maintain current lead times and deliveries.

GRADIENTS AND VIGNETTES

Ensure gradients created in illustrator are set up at 2400dpi in attributes and document setup. To prevent banding it is best to create gradients in Photoshop.

Also due to uniqueness of printing on plastic, gradation should not be 0% to 100% If gradations are created at about 6% to 99% they have less tendency for banding.

LOGOS

Any logos included in the file must be supplied as vector drawn images, not bitmap or raster. This ensures the image remains crisp and clear. Alternatively, whilst not preferred a high quality logo can be used. If you are unable to supply a suitable logo, we are able to do with for you from supplied artwork at an extra charge.

GENERAL REQUIREMENTS

Frames/borders must not be used to mark the trim if you do not want them to be printed.

Files can be sent via email to your salesperson.

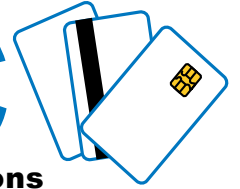

PREPRINTED CARD SETUP

LANDSCAPE – document size MUST be 91mm x 60mm

PORTRAIT – document size MUST be 60mm x 91mm

TRIMMED SIZE - 85mm x 54mm

HALF-PANEL RIBBON

If you are using a half-panel ribbon for printing, please ensure any colour is to left of green dashed line.

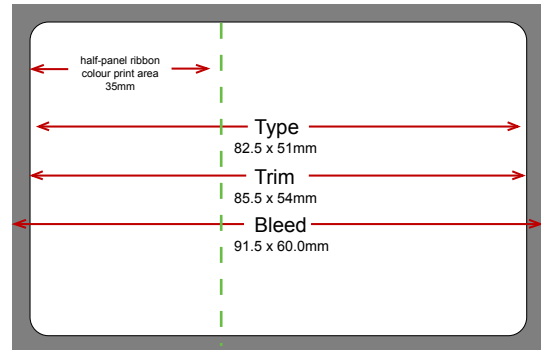

Standard Card with Magnetic Strip

TIP: Avoid designing borders close to the edge.

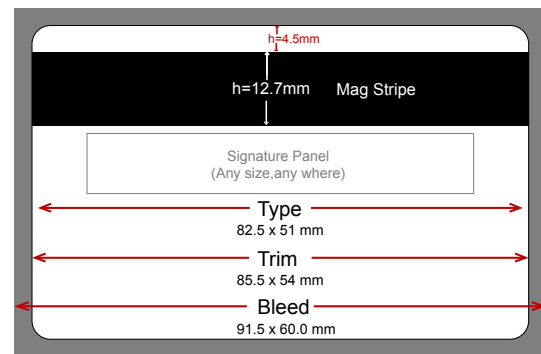

Standard Card with IC Chip

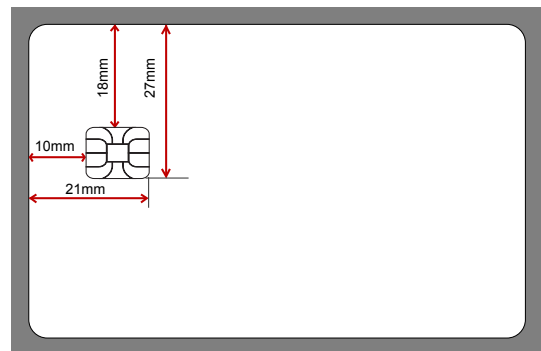

TIP: Signature panels can be any size as long as they are square or rectangle in shape. No rounded corners or text on the signature panel are allowed.

ARTWORK

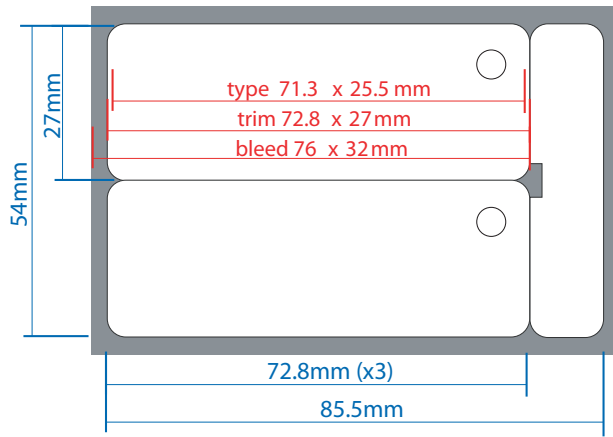

Double Name badge (without holes)
Or
Double Key tag (with holes)

TIP: Avoid designing borders close to the edge.

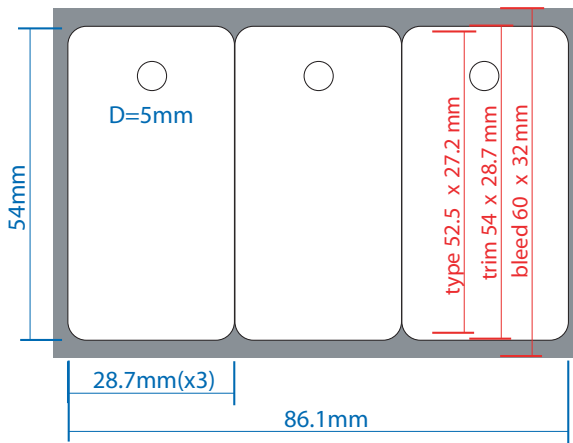

Triple Key Tags (with or without holes)

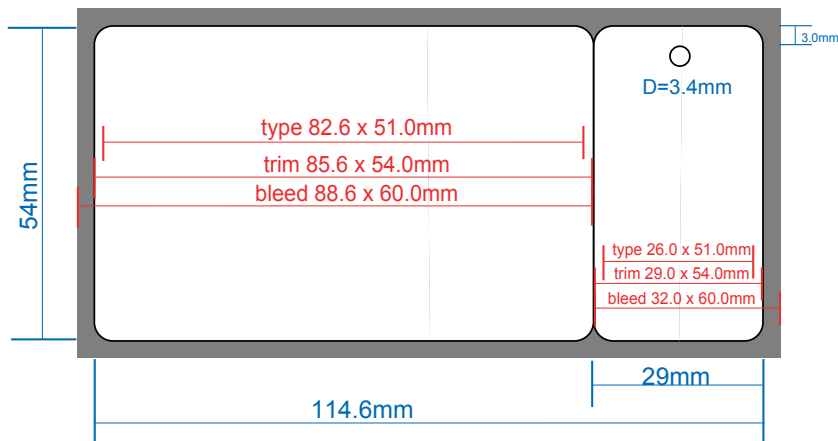

Single Key-tag & Mini Tag

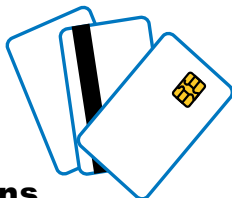

QUEENSLAND

Unit 4, 106 Fison Ave
Eagle Farm QLD 4007
Tel: (07) 3868 7300
Fax: (07) 3868 7350

NEW SOUTH WALES

Unit 51, 6 Herbert St
St Leonards NSW 2065
Tel: (02) 9436 4766
Fax: (02) 9436 4605

VICTORIA

Suite 421, 1 Queens Rd
St Kilda Rd Towers
Melbourne VIC 3004
Tel: (03) 9863 9744
Fax: (03) 9863 9745