

P330i - How to Clean

1. Leave the Printer power on, or turn it on if it was off.
2. Initiate the cleaning process by either of the following methods:
 - At the printer, press and hold the panel button for several seconds, until the LCD Panel displays the message **REMOVE RIBBON THEN CLOSE HEAD.**
 - From the computer, enter the P330i Printer Tools software, and click on the CLEAN button. The LCD Panel will display the message **REMOVE RIBBON THEN CLOSE HEAD.**
3. Open the Main Cover, release the Print Head Carriage, and remove the ribbon. Then close the Print Head Carriage. The LCD Panel will display the message **EMPTY FEEDER & PRESS BUTTON.**
4. Open the Card Feeder Cover and remove cards from the Card Feeder. The last card is difficult to remove; leave it in place. Press the Panel Button on the front of the printer. The card remaining in the feeder will be ejected. The LCD Panel will then display the message **LOAD CLEANING CARD IN FEEDER.**
5. Place a pre-saturated Cleaning Card into the Card Feeder. The Cleaning Card will automatically feed into the printer and the cleaning process will start (there is a several second delay after the Cleaning Card feeds before the cleaning movement starts). While the cleaning process is underway, the LCD Panel will display the message **CLEANING PRINTER.**
6. At the conclusion of this part of the cleaning process, the Cleaning Card will be ejected, and the LCD Panel will display the message **PRESS BUTTON TO CONTINUE.**
7. After the user presses the panel button, the LCD Panel will display the message **FEED LONG CLEANING CARD IN EXIT.** Insert the long end of the long cleaning card into the card exit (directly above the Output Hopper). If the user inserts a “regular” cleaning card into the card exit, the LCD Panel will display the message **INVALID CARD, PRESS BUTTON** until the user presses the panel button and inserts the long cleaning card into the card exit.

Note • This cleaning procedure uses two cleaning cards. One cleaning card is the size of a regular plastic card, and is referred to as the “cleaning card.” The other is elongated, with a wider section at one end; it is referred to as the “long cleaning card.” **Note** • If the user does nothing at this point (i.e., does not insert the long cleaning card), after a timeout the LCD Panel display will change to **CLEAN PRINTER.** The printer will be able to print, but the LCD Panel will continue to display **CLEAN PRINTER.**

This limited cleaning does not do a thorough cleaning, but may be performed if no “long cleaning cards” are available.

To restore the display to **READY**, you will need to perform a complete cleaning process, using both short and long cleaning cards, from step 2 above through step 9 below.

8. The long cleaning card will automatically feed into the printer and the printing process will continue. The LCD Panel will again display the message **CLEANING PRINTER.**
9. When the cleaning process is completed, the long cleaning card will be ejected and the LCD Panel will display the message **READY**, indicating that the printer is ready to resume normal printing operations.
10. Discard both cleaning cards after a single use.

Note • Do not use previously used cleaning cards.

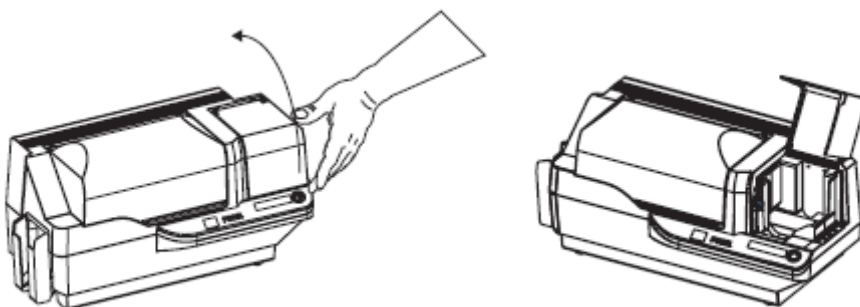

P330i - Loading a Ribbon & Change Cleaning Roll



Electrostatic Discharge Caution • **DO NOT TOUCH** the Print Head or the electronic components on the Print Head Carriage. Discharges of electro-static energy that accumulate on the human body or other surfaces can damage the Print Head or other electronic components used in the printer.



Note • Avoid any direct contact with the print head to prevent transfer of oils or contamination. Outside of normal operation, only the Zebra-approved cleaning materials should come in contact with the print head.



Caution • Do not touch the print head if the printer has been in service within the last 10 minutes. It could be very hot and cause a burn.

i Series Printers require the use of *i* Series ribbons for full colour printing. The Resin Thermal Transfer and Dye Sublimation ribbons for P330*i* are specifically designed for your P330*i* Printer.

1. Place the printer power switch in the OFF (0) position.
2. If the printer's Main Cover is closed:

- a. Open the printer's Main Cover; lift it by the lip at the bottom front as shown in the figure below left.
- b. Raise the Print Head Carriage by pressing the release latch to the left (toward the output hopper) and lifting as shown below to about a 45° angle. The Print Head Carriage will stay in that position, as shown at the right below.

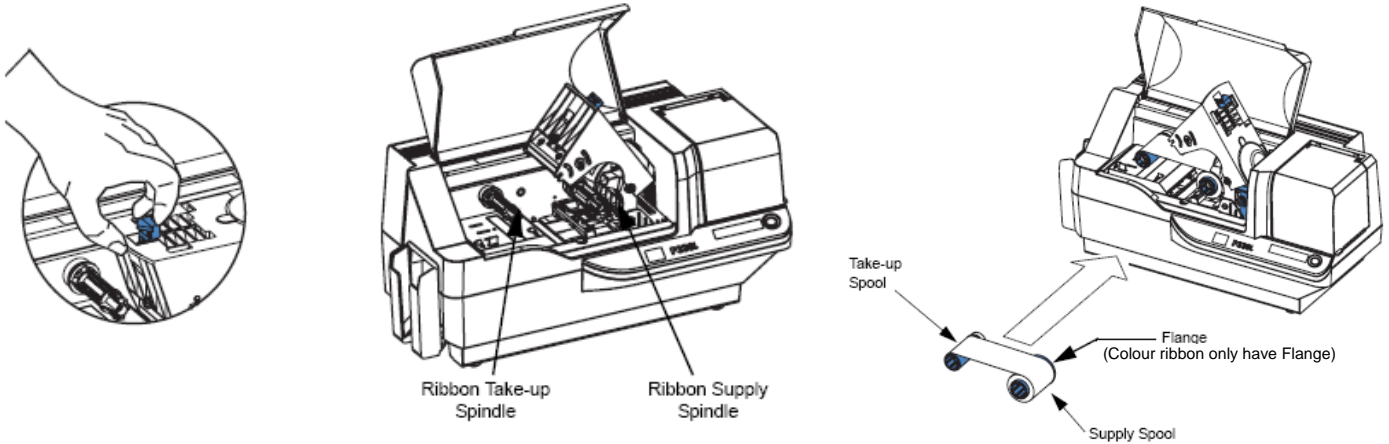

3. Locate the Ribbon Supply Spindle and the Ribbon Take-up Spindle (see above). Load ribbon onto the supply spindle (under the print head carriage) **flange side in**, and load the empty core (with tape attached) onto the take-up spindle. Make sure the ribbon comes off the top of the supply spindle and feeds to the top of the take-up spindle.
4. Gently press the print head carriage down until it is fully lowered, as shown below. Very little force is necessary to perform this step.

When you change the ribbon you should also change the card cleaning roll.

1. Remove the Cartridge Frame and the Adhesive Roller from their packaging. Insert the Adhesive Roller into the Cartridge Frame, as shown below. To avoid contamination, always hold the frame and the roller by the ends.
2. Peel the protective wrapper from the Adhesive Roller.

